

LB2-UC30-L1 Cabinet loudspeaker, 30W, white

www.boschsecurity.com



BOSCH
Invented for life



- ▶ High-fidelity music and speech reproduction
- ▶ Selectable 8 ohm, 70 V and 100 V inputs
- ▶ Compact yet robust ABS enclosure
- ▶ Supplied with adjustable mounting bracket
- ▶ Complies with international installation and safety regulations

The LB2-UC30-L1 Premium-sound cabinet loudspeaker is intended for clear reproduction of speech, foreground and background music to be used in general indoor and outdoor applications. The Premium-sound cabinet loudspeaker consists of a 30 W model, available in a light color. The loudspeaker has selectable 8 ohm, 70 V and 100 V inputs. The ABS cabinets are fitted with aluminum front-grilles and standard supplied with aluminum bracket. Typical applications are: theme bars, music restaurants, theme parks, retail outlets, audio visual, boardrooms and offices, exhibition areas, showrooms, fitness centers and presentation environments.

Certifications and approvals

Quality assurance

All Bosch loudspeakers are designed to withstand operating at their rated power for 100 hours in accordance with IEC 60268-5 Power Handling Capacity (PHC) standards. Bosch has also developed the Simulated Acoustical Feedback Exposure (SAFE) test to demonstrate that they can withstand two times their rated power for short durations. This ensures improved reliability under extreme conditions, leading

to higher customer satisfaction, longer operating life, and lessens the chance of failure or performance deterioration.

Safety	acc. to EN 60065
Water and dust protection	acc. to EN 60529 Water Protection
Self extinguishing	acc. to UL94 V 0
Chlorine resistant	acc. to IEC60068-2-42
Corrosion resistant	acc. to IEC60068-2-52
Salt mist	acc. to IEC60068-2-11

Region	Regulatory compliance/quality marks	
Global	DOC	Declaration of Compliancy IEC 60068-2-60 (Mixed gas corrosion test)
Europe	CE	DECL IP LB2-UC15-D1_L1 and LB2-UC30-D1_L1
	CE	DECL EC LB2-UC30-L1

Installation/configuration notes

The cabinets include a built-in transformer that offers a selection of nominal full power, half power, quarter power or eight power radiation (i.e. in 3 dB steps) for 70 V, 100 V or 8 Ohm bypass.

Selection is done by a convenient switch on the rear enclosure.

A two meter long twin-core loudspeaker cable (in matching color with the cabinet) is connected to the loudspeaker. The core ends are stripped ready for use. The mounting brackets are fitted with anti-theft torx screws, covered with plastic covers in matching color of the cabinets.

The cabinets can be mounted horizontally to allow the loudspeaker to be directed up or down, or vertically to allow left and right rotation by means of a steel U-shaped wall bracket (standard supplied).

The rotatable logo can be easily adjusted to match the mounting orientation.

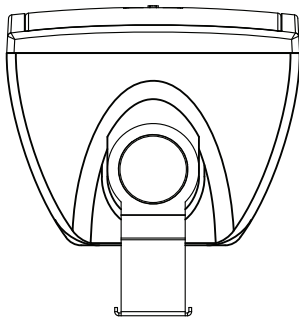
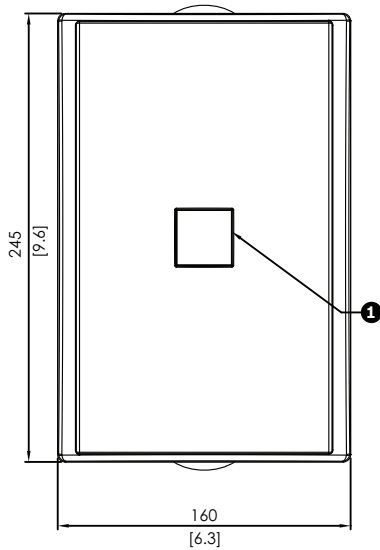

Front and top view mm (in.). (1) Rotatable logo

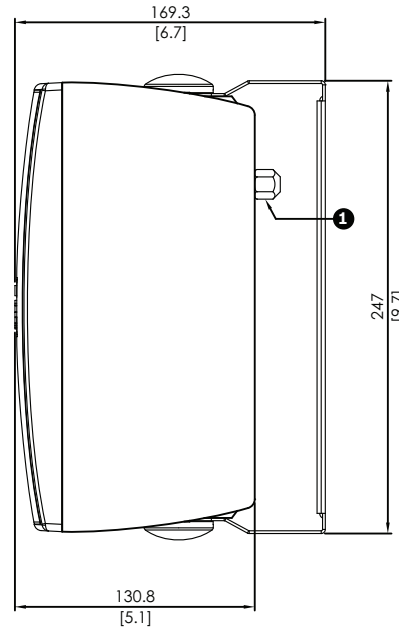

Side view mm (in.). (1) Power tapping switch

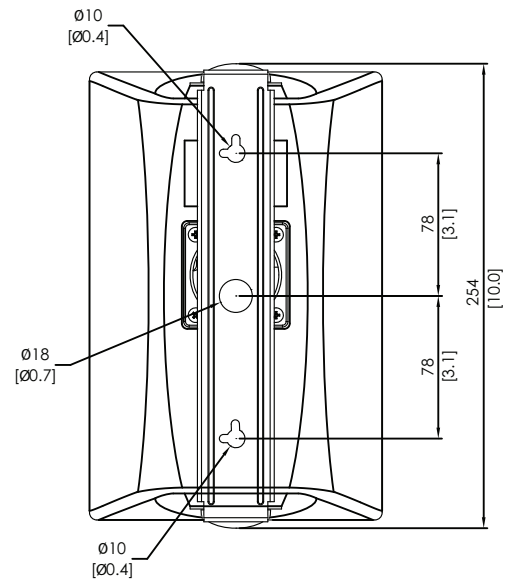

Rear view mm (in.)

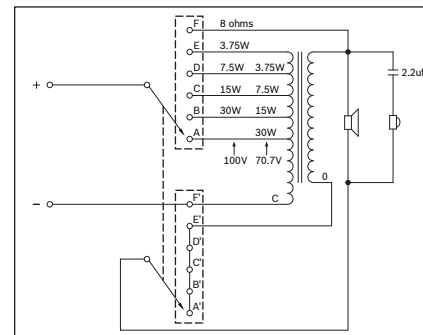

LB2-UC30 Circuit diagram

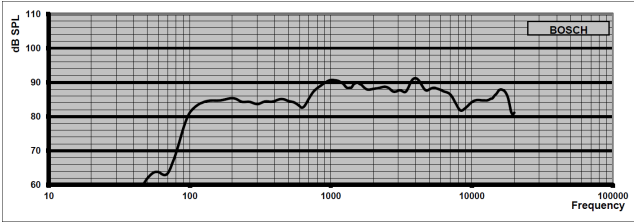

LB2 UC30 Frequency response

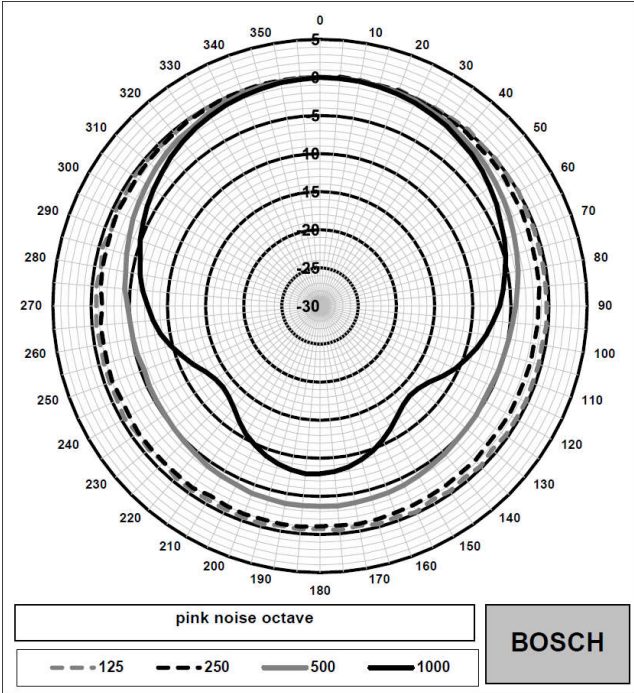

LB2 UC30 Polar diagram horizontal (low frequency).
Normalized at 0 degrees axis

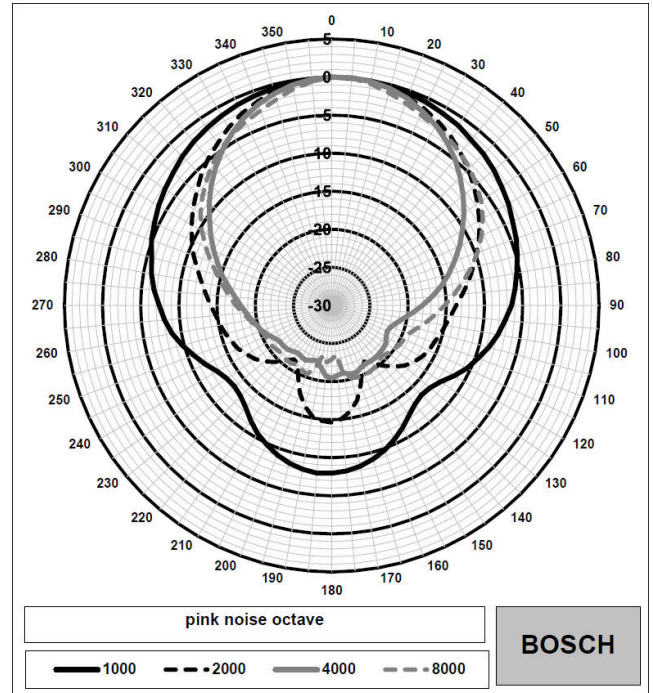

LB2 UC30 Polar diagram horizontal (high frequency).
Normalized at 0 degrees axis

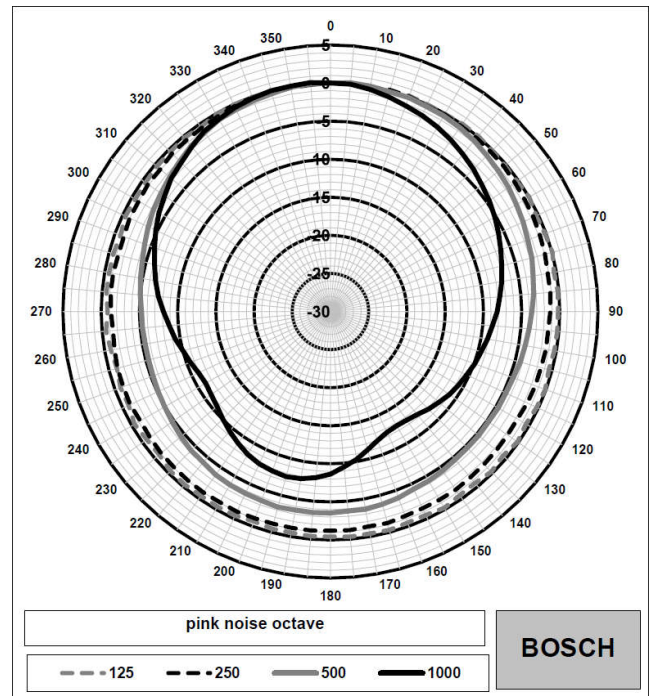

LB2 UC30 Polar diagram vertical (low frequency).
Normalized at 0 degrees axis

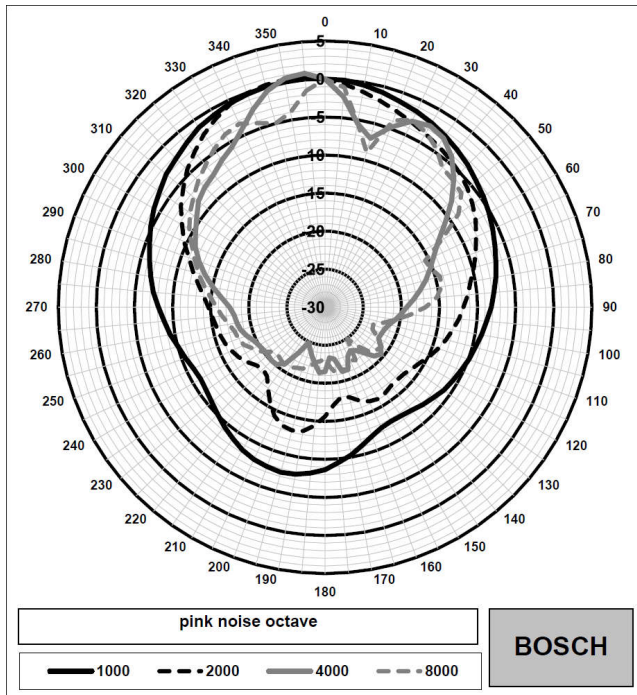

LB2 UC30 Polar diagram vertical (high frequency).
Normalized at 0 degrees axis

Octave band sensitivity *

	Octave SPL 1W/1m	Total octave SPL 1W/1m	Total octave SPL Pmax/1m
125 Hz	84.0	-	-
250 Hz	84.4	-	-
500 Hz	85.6	-	-
1000 Hz	90.2	-	-
2000 Hz	90.1	-	-
4000 Hz	93.0	-	-
8000 Hz	88.6	-	-
A-weighted	-	87.7	101.6
Lin-weighted	-	87.9	102.2

Octave band opening angles

	Horizontal	Vertical
125 Hz	360	360
250 Hz	360	360
500 Hz	360	360
1000 Hz	166	140
2000 Hz	98	104

4000 Hz	83	76
8000 Hz	94	54

Acoustical performance specified per octave
* (all measurements are done with a pink noise signal;
the values are in dB SPL)

Parts included

Quantity	Component
1	LB2-UC30-L1
1	Mounting bracket
1	Installation instructions

Technical specifications

Electrical*

Product	LB2-UC30-L1
Description	Premium-sound Cabinet Loudspeaker
Maximum power	45 W
Rated power (PHC)	30 W
Power tapping	30/15/7.5/3.75 W
Sound pressure level at rated power / 1 W (1 kHz, 1 m)	105/90 dB (SPL)
Effective frequency range (-10 dB)	100 Hz to 19 kHz
Opening angle at 1 kHz / 4 kHz (-6 dB)	166° / 83° (hor.), 140° / 76° (ver.)
Rated input voltage	15.5/70/100 V
Rated impedance	8/163/333 ohm
Transducers	127 mm (5") woofer, 13 mm (0.51") dome tweeter
Connection	2 m (78.8 in.) two-wire cable

* Technical performance data acc. to IEC 60268-5

Mechanical

Dimensions (HxWxD)	245 x 160 x 131 mm (9.6 x 6.3 x 5.1 in.)
Weight	Approx. 2.4 kg (5.29 lb)
Color	White (RAL 9010) (L)

Environmental

Operating temperature	-25 °C to +55 °C (-13 °F to +131 °F)
Storage and transport temperature	-40 °C to +70 °C (-40 °F to +158 °F)
Relative humidity	<95%

Ordering information

LB2-UC30-L1 Cabinet loudspeaker, 30W, white
Cabinet Loudspeaker 30 W, ABS enclosure, U-bracket mounting, fixed 2 m twin-core connection cable, water- and dust protected IP 65, white RAL 9010.
Order number **LB2-UC30-L1**

Represented by:

Europe, Middle East, Africa:
Bosch Security Systems B.V.
P.O. Box 80002
5600 JB Eindhoven, The Netherlands
Phone: + 31 40 2577 284
emea.securitysystems@bosch.com
emea.boschsecurity.com

Germany:
Bosch Sicherheitssysteme GmbH
Robert-Bosch-Ring 5
85630 Grasbrunn
Germany
www.boschsecurity.com

North America:
Bosch Security Systems, LLC
130 Perinton Parkway
Fairport, New York, 14450, USA
Phone: +1 800 289 0096
Fax: +1 585 223 9180
onlinehelp@us.bosch.com
www.boschsecurity.us

Asia-Pacific:
Robert Bosch (SEA) Pte Ltd, Security Systems
11 Bishan Street 21
Singapore 573943
Phone: +65 6571 2808
Fax: +65 6571 2699
apr.securitysystems@bosch.com
www.boschsecurity.asia