

PUBLIC ADDRESS / SPEAKERS / CEILING

# GAT-601

100 V LINE TRANSFORMER CEILING SPEAKER

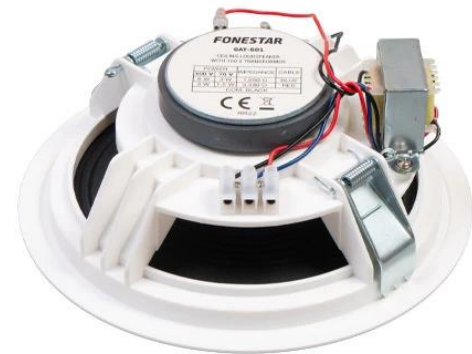
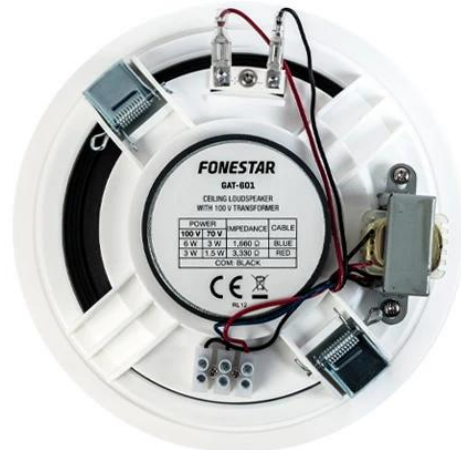

- ✓ Crisp and clean sound
- ✓ Quick installation system
- ✓ ABS built with fireproof case and steel grille

ESPECIALLY RECOMMENDED IN:



Hospitality



Retail



Hotels



All sectors



+ Info:  
<https://fonestar.com/GAT-601>

## DESCRIPTION

Ceiling loudspeaker it delivers crisp, clean sound, perfect for both speech and background music. It has a body made of ABS and a protective steel grille that guarantees its integrity. It has a quick installation system that minimizes assembly time. Perfect for background music and voice announcements in 100 V line installations in offices, small shops, restaurants, waiting rooms, etc.

## TECHNICAL CHARACTERISTICS

FEATURES	Ceiling loudspeaker with 100 V line transformer and round grille.
POWER	10 W maximum, 6 W RMS
LOUDSPEAKERS	6 ½" double cone
RESPONSE	140-20,000 Hz
IMPEDANCE	6 W RMS@100V (1,660 Ohm) 3 W RMS@100V (3,330 Ohm)
SENSITIVITY	92 dB ±3 dB at 1 W/1 m
MATERIAL	ABS and steel grille
COLOUR	White (RAL 9003)
DIMENSIONS	188 mm Ø x 80 mm depth
HOLE	168 mm Ø
WEIGHT	0.6 kg
	Rapid installation system



+ Info:  
<https://fonestar.com/GAT-601>

## SPL vs Frequency

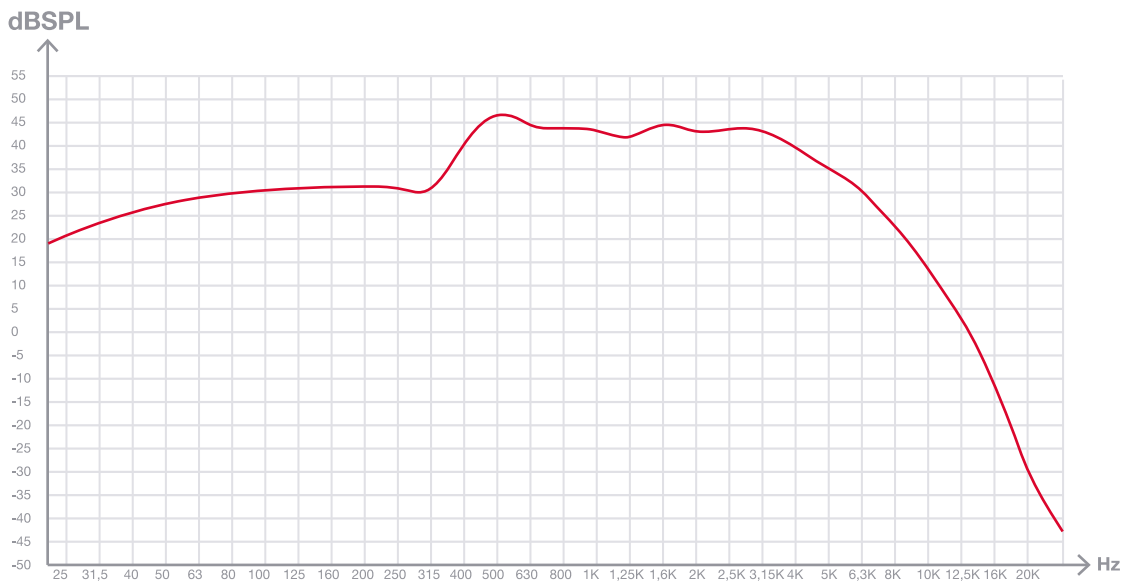

## SPL vs Angle

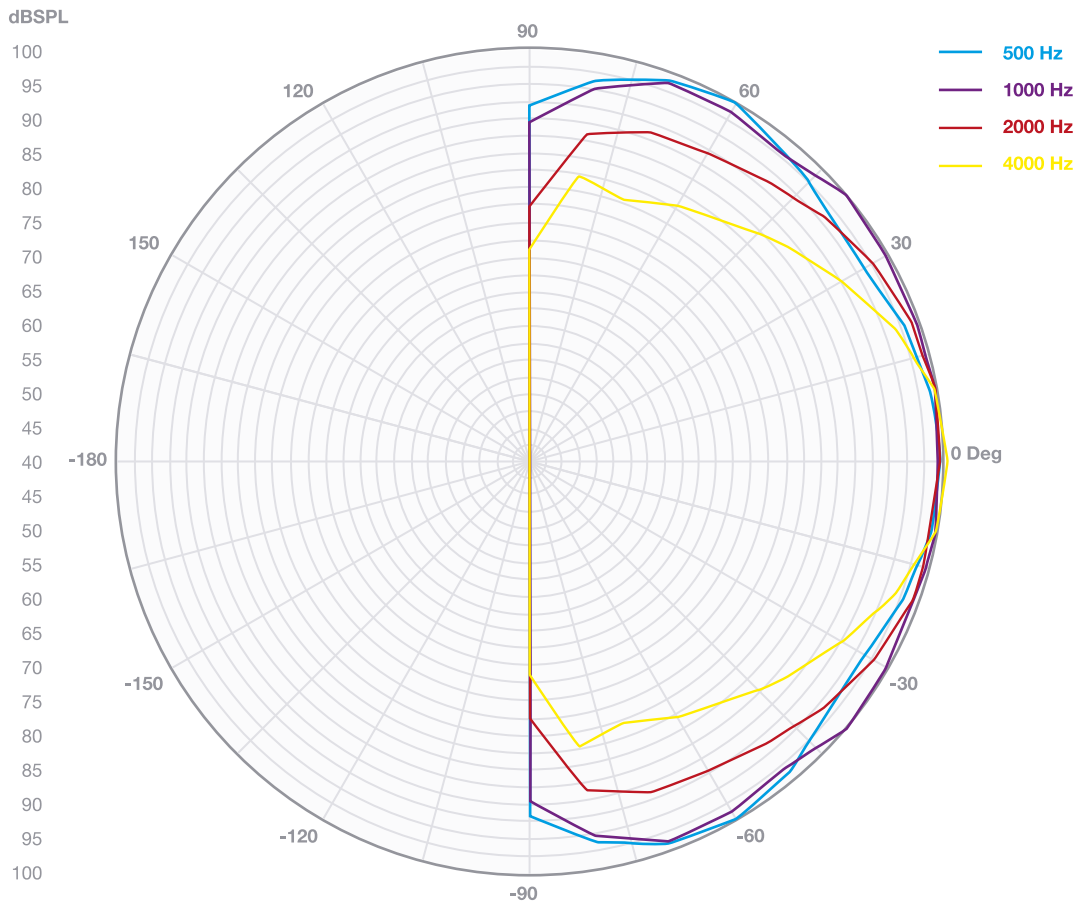

+ Info  
<https://fonestar.com/GAT-601>

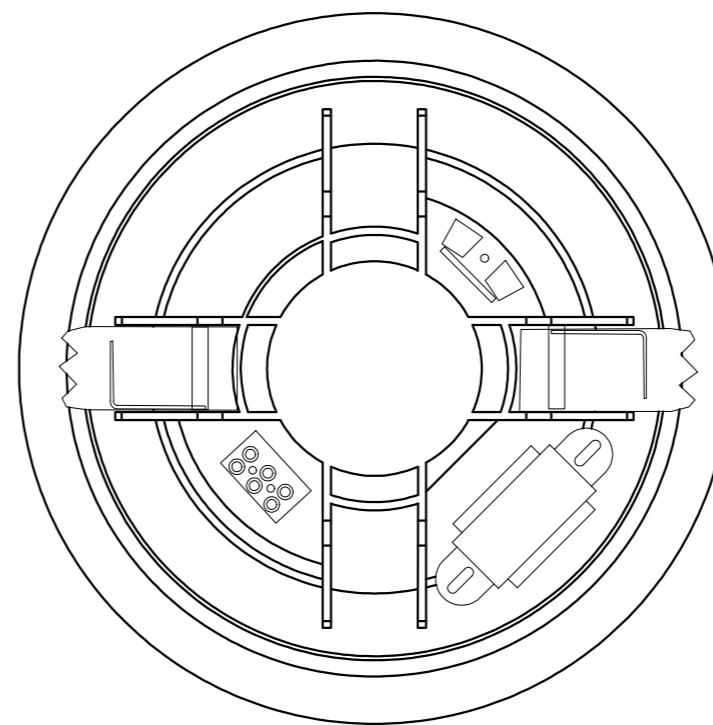
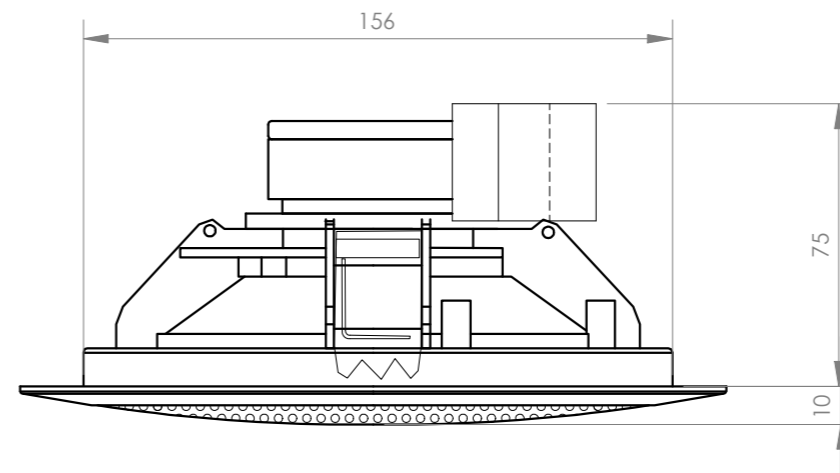
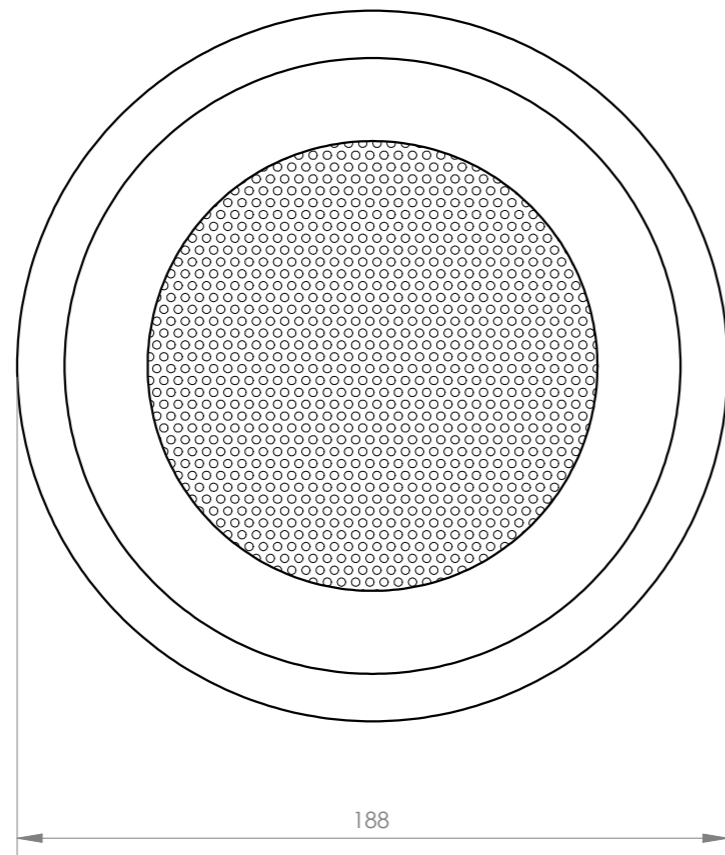

<b>FONESTAR</b>	Model	Description	Units	Scale
	GAT-601	100 V LINE TRANSFORMER CEILING SPEAKER	mm	1:2