

PUBLIC ADDRESS / SPEAKERS / CEILING

GAT-501

CEILING LOUDSPEAKER WITH 100 V LINE TRANSFORMER

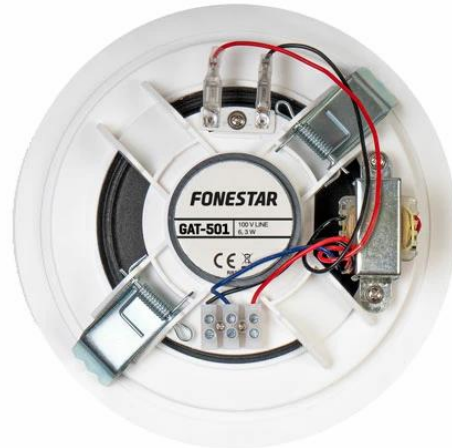

- ✓ Crisp and clean sound
- ✓ ABS built with fireproof case and steel grille
- ✓ Quick installation system

ESPECIALLY RECOMMENDED IN:



Hospitality



Retail



Hotels



All sectors



+ Info:
<https://fonestar.com/GAT-501>

DESCRIPTION

Ceiling loudspeaker for sound reinforcement. It offers a clear and crisp sound, perfect for voice and background music. Built in ABS and steel grille that guarantees its integrity. It has a quick installation system that minimises assembly time. For background music and voice announcements in 100 V line installations in offices, shops, restaurants, waiting rooms, etc.

TECHNICAL CHARACTERISTICS

FEATURES	Ceiling loudspeaker with 100 V line transformer and round grille.
POWER	10 W maximum, 6 W RMS
LOUDSPEAKERS	5" double cone
RESPONSE	140-15,000 Hz
IMPEDANCE	6 W RMS@100V (1,660 Ohm) 3 W RMS@100V (3,330 Ohm)
SENSITIVITY	90 dB ±3 dB at 1 W/1 m
MATERIAL	ABS and steel grille
COLOUR	White (RAL 9003)
DIMENSIONS	175 mm Ø x 60 mm depth
HOLE	150 mm Ø
WEIGHT	0.5 kg
	Quick installation system



+ Info:
<https://fonestar.com/GAT-501>

SPL vs Frequency

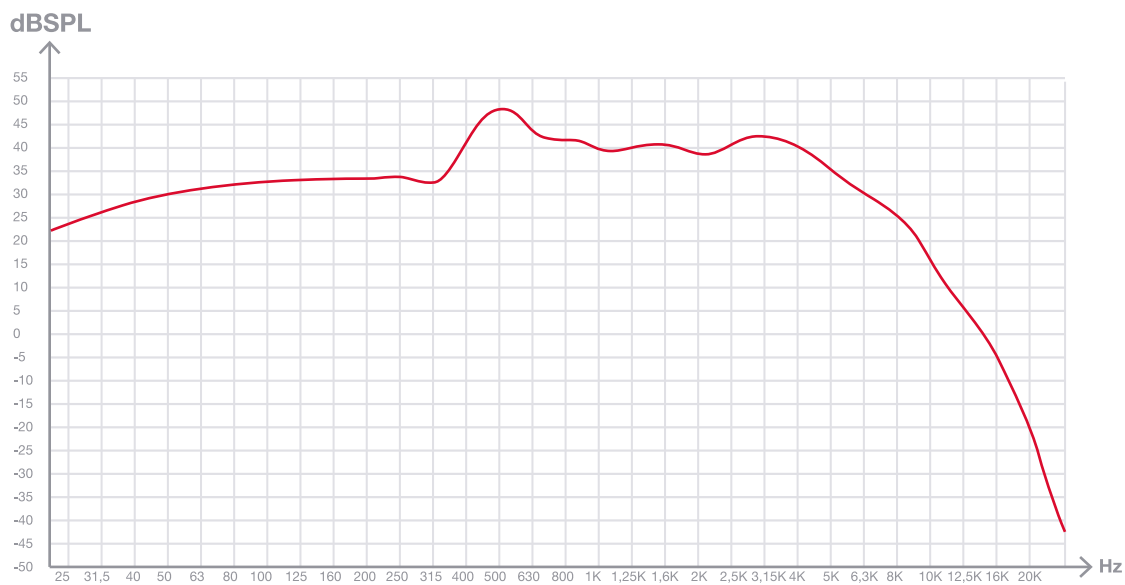

SPL vs Angle

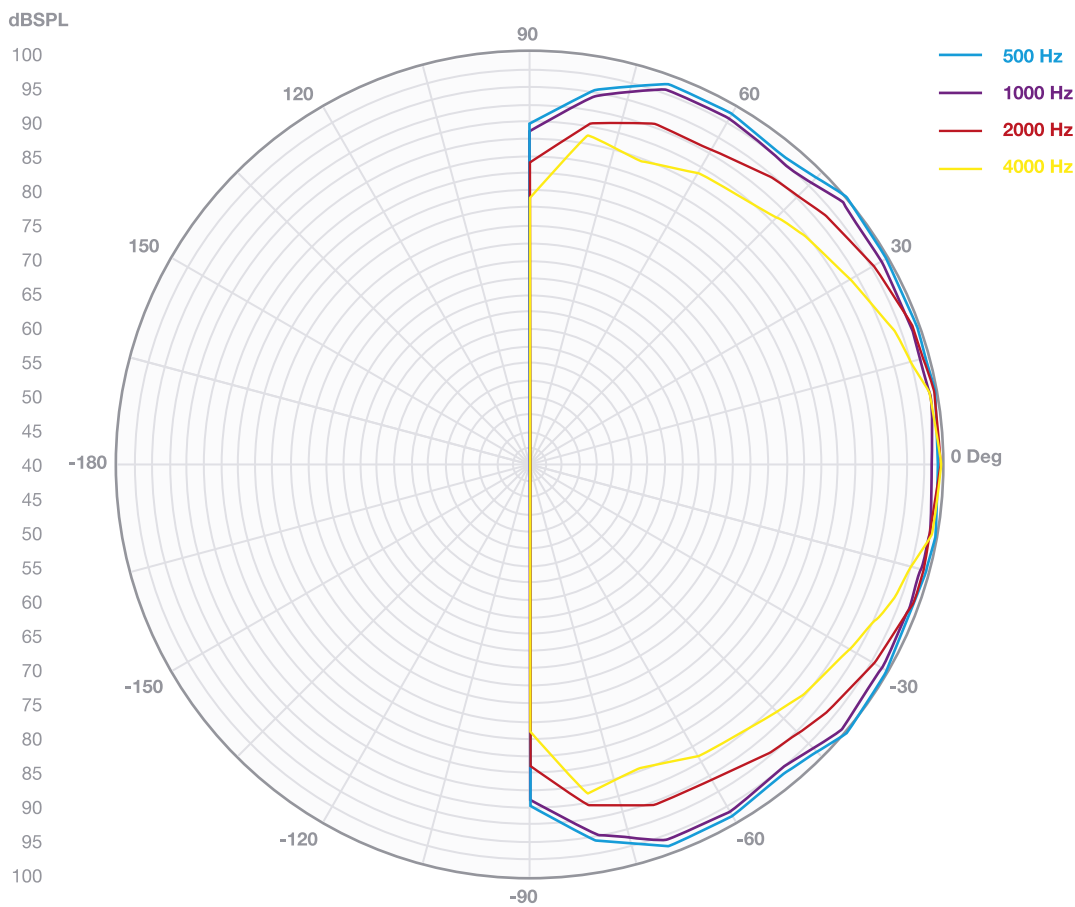

+ Info
<https://fonestar.com/GAT-501>

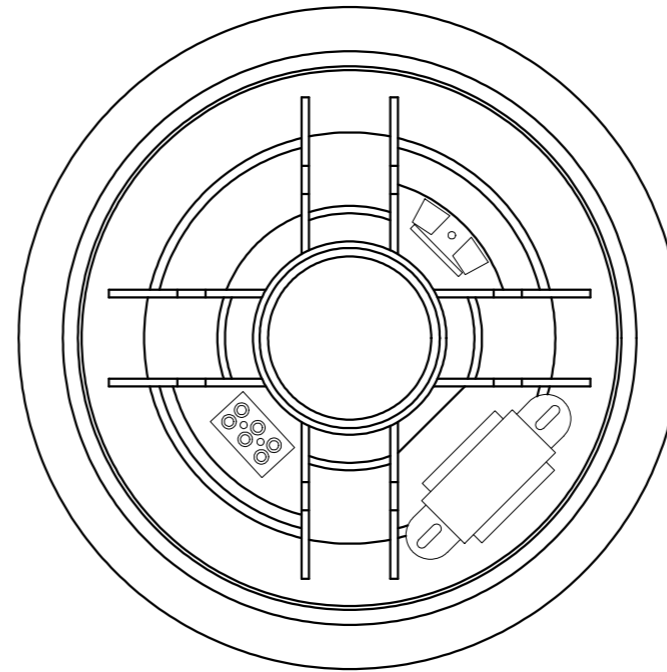
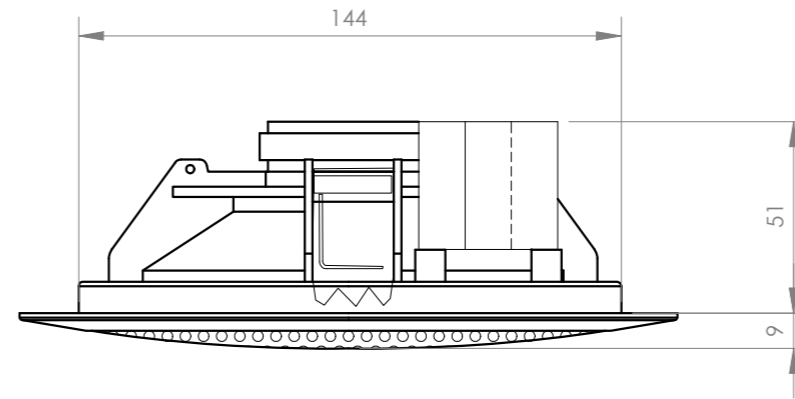
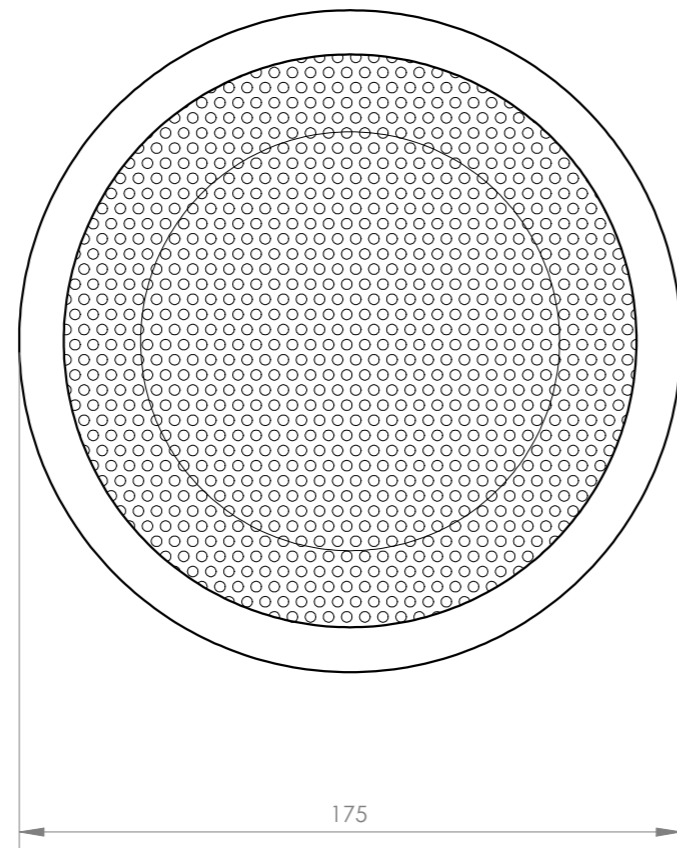

FONESTAR	Model	Description	Units	Scale
	GAT-501	100 V LINE TRANSFORMER CEILING SPEAKER	mm	1:2